

EMRENT65E

60cm Stainless Steel Electric Fan Forced Oven



A ROBUST, EASY TO USE OVEN

Intuitive, easy to understand controls. This is a great oven for group houses and rental properties. This oven is fit for purpose, great performance without a lot of fuss

5 COOKING FUNCTIONS

Equipped with efficient fan forced cooking, closed door grilling with or without fan assistance, defrost and an oven light to illuminate the cooking.

10 AMP PLUG IN CONNECTION

This oven plugs in like a toaster. So much easier to install, replace or service. There is no compromise in performance and energy costs remain lower with less electricity being consumed.

TRIPLE GLASS DOOR

Triple Glass ventilated door keeps surface temperatures down. Much more comfortable and safer for the user. The large window provides a clear view of the cooking process.

TECHNICAL FEATURES

MAIN FEATURES	
Gross Volume	67 Litres
Usable volume	57 Litres
Side Racks	5 Shelf Levels
Control	Knob Controls
Cooling Fan	Automatic
Timer	60 Minute timer
Maximum Temperature	260 C
Total Max Power Consumption	2300W
Electrical Connection	10amp Plug in
Removable door	For cleaning
Oven Internal Finish	Black porcelain enamel
Power cord length	1.2 metre
10amp Plug	Fitted
DESIGN FEATURES	
Colour	Black Glass, Stainless
Oven Light	Halogen
Inner Door	Full Glass - Removable
Handle	Anodized aluminium
Door Construction	Triple Glass Ventilatted
Control knobs	Anodized aluminium
INCLUDED ACCESSORIES	
Side Racks	2 - snap out for cleaning
Wire Shelves	2 - with 5 positions
Grill Tray	1 - porcelain enamel
Insert Rack for Grill Tray	1 - holds food off grill tray
Installation kit	Screws and fittings
Instruction Manual	Includes installation guide

OVEN CAVITY	
Rear fan	Fan forced function
Side Chromed Racks	Removable
Cooking Elements	Grill, rear circular
Internal Oven Dimensions mm	470W x 340H x 420D
OVEN DOOR	
Full glass inner door	Easily removed
Triple glass door	Insulates oven
Removable inner glass	Allows cleaning
OVEN COOKING FUNCTIONS	
Cooling fan - Automatic	Surfaces stay cool
Thermostat control	Accurate temp control
1. Fan Forced	Fast, efficient
2. Fan assisted Grill	Door closed efficiency
3. Static Grill	Door closed efficiency
4. Defrost	Speeds defrosting
5. Oven light	Lights the cavity
DIMENSIONS & WEIGHTS	
Unpacked Weight	35Kg
Packed Weight	40Kg
Packed Dimensions	660W x 650H x 650D
Unpacked Dimensions	595W x 595H x 570D
WARRANTY	
3 Years Parts and Labour	In home service
BAR CODE	
0793618352479	

EMRENT65E

60cm Stainless Steel Electric Fan Forced Oven

INSTALLATION NOTES

Overall dimensions

This model oven uses the conventional dimensions of the majority of 60cm built in ovens making it an ideal oven to use for replacement purposes. In most cases the oven will fit into existing cupboard spaces without need for modification to the kitchen.

Electrical Connection

The oven has a 1.2M cord with a 10 amp plug fitted. This is a simple plug in connection. The oven should be installed with a unique circuit, not sharing the connection with other appliances. It is an important requirement.

3 Year Warranty

A full nationwide 3 Year Warranty applies.

Proof of purchase and proof of correct installation by a licensed installer is required for warranty service.

Call Glem Gas Australasia on 1 300 307 917 for details or send an email to info@glemgas.com.au and we will respond promptly.

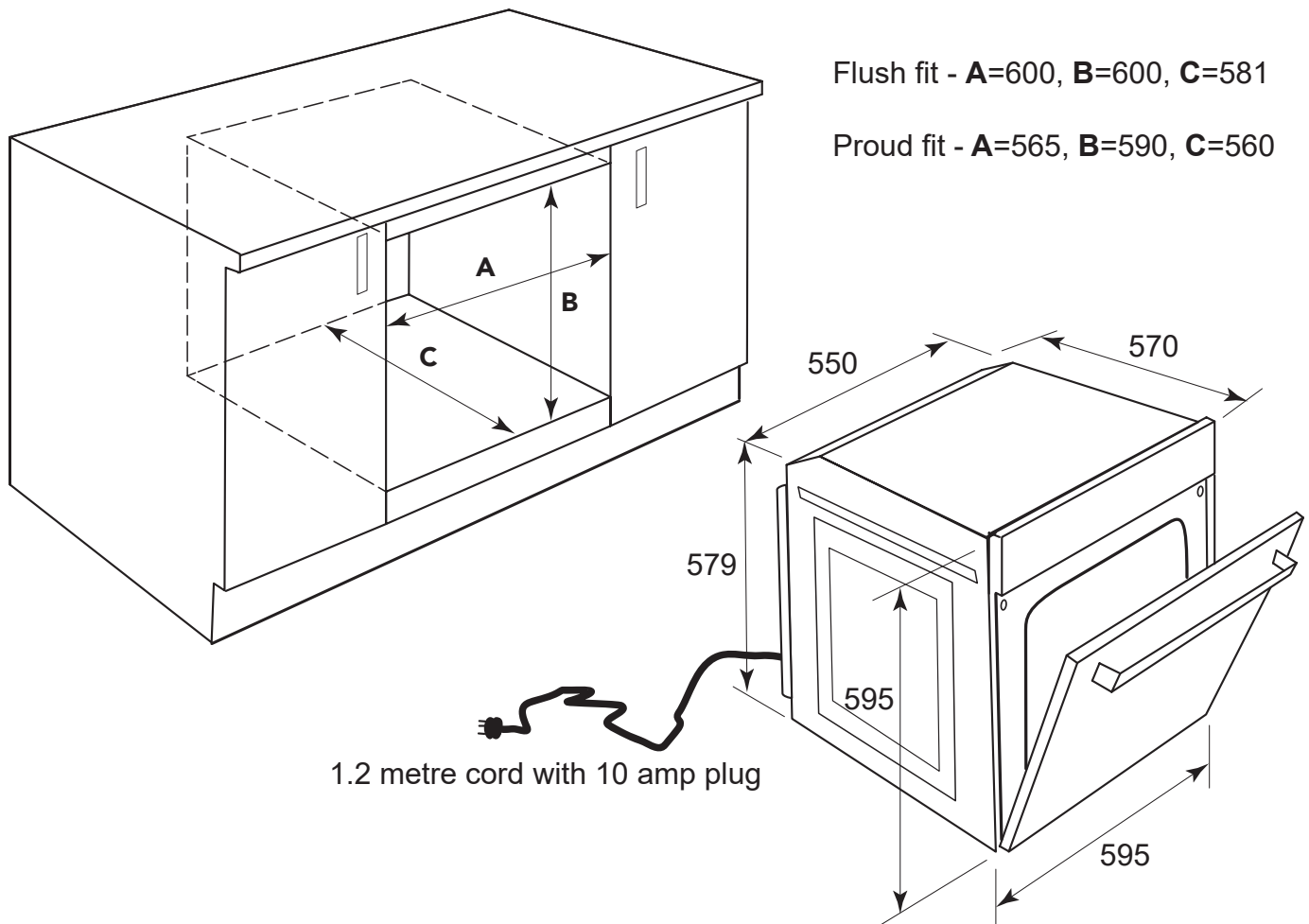

Please note:

Every effort has been made to ensure this information is correct. However, due to product improvement Glem reserves the right to make changes to products without prior notice.